

Version 40 , 50, 65.

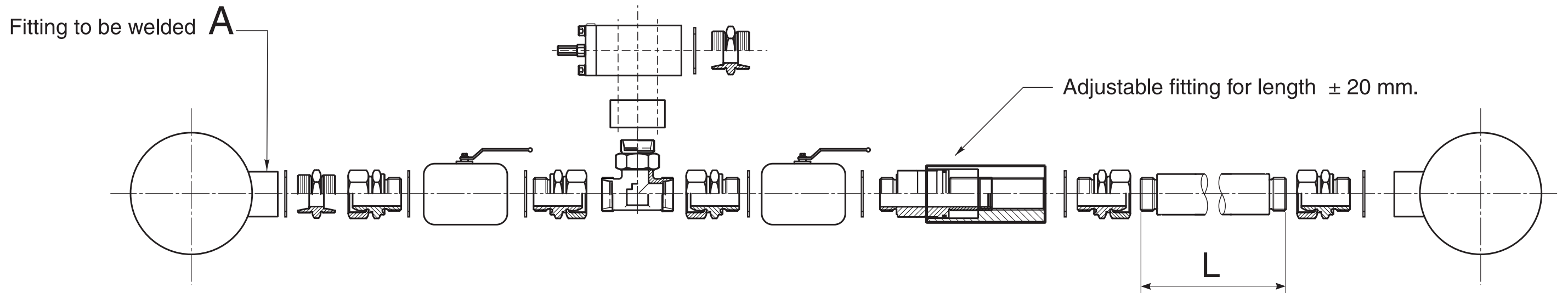

Version 41, 51, 66.

L = PIPE LENGTH

Version	V.C.	A	Steel pipes GMV Sweden
40	1 ³ / ₄ - 1 ¹ / ₂	G 1 ¹ / ₂	2 Jacks without shut off valves
41	1 ³ / ₄ - 1 ¹ / ₂	G 1 ¹ / ₂	2 Jacks with shut off valves
50	2"	G 1 ¹ / ₂	2 Jacks without shut off valves
51	2"	G 1 ¹ / ₂	2 Jacks with shut off valves
65	2 ¹ / ₂ "	G 1 ¹ / ₂	2 Jacks without shut off valves
66	2 ¹ / ₂ "	G 1 ¹ / ₂	2 Jacks with shut off valves