

Valve 1" ¼ - 1" ½

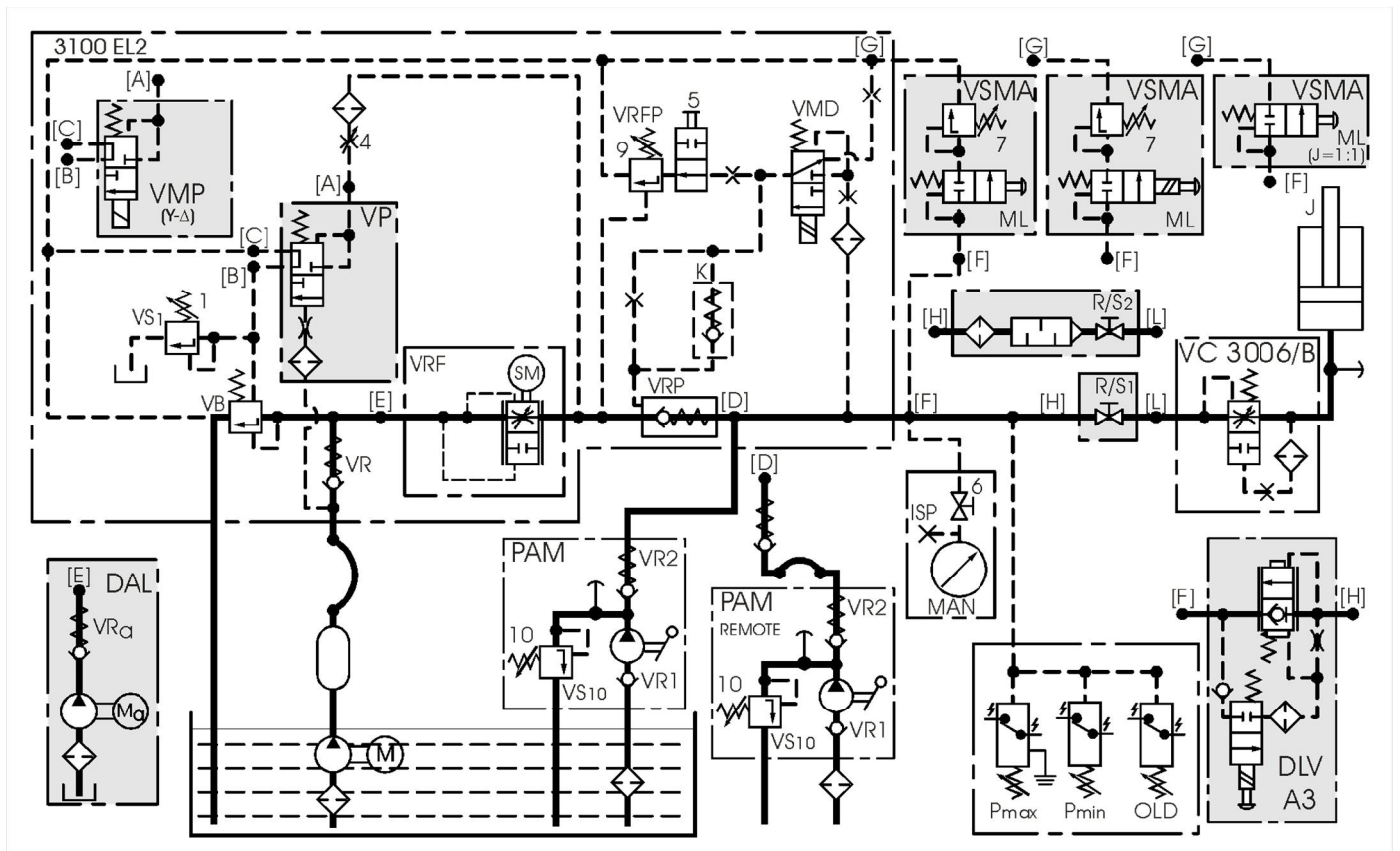
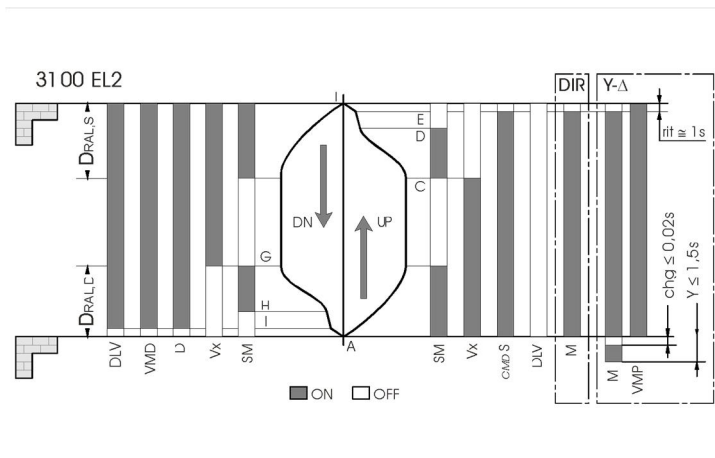

ABBREVIATIONS FOR ALL THE GMV HYDRAULIC SCHEMES

1	Adjustment screw : safety valve (pressure relief)	PAM	Hand pump
2	Adjustment screw : levelling speed	P_{max}	Maximum pressure limit switch
3	Adjustment screw : deceleration (upward / downward)	P_{min}	minimum pressure limit switch
4	Adjustment screw : acceleration (upward)	PT	Pressure transducer
5	Shut-off valve / Screw for rupture valve test	R/S	Ball valve (1) / Silencer (2)
6	Shut-off valve for pressure gauge exclusion	RDY	Ready - Ready signal (card output to control panel)
7	Adjustment screw : ram pressure (only 2:1 acting jacks)	RIT	Delay
8	Adjustment screw : high speed	RO	Oil heating resistance
9	Adjustment screw : downward speed compensation	RT	Motor thermistors
10	Adjustment screw : safety valve (PAM)	RUN	Run - Start signal (card output to control panel)
3010, 3100	Valve 3010 (complete)	S	Adjustment screw : soft-stop
BOX	Interface box (Valve / Control panel)	S1 (VRP)	VRP closing control sensor
C1	VRP chamber	S2 (VBC)	VB closing control sensor
C2	Inlet chamber	S3 (VBO)	VB opening control sensor
C3	VB outlet chamber	SCC	Starting Current Control
C4	VRP pilot spool chamber	SM	Stepping motor
CARD	Electronic card	TO	Oil thermostat
CHG	Exchange	TT	Temperature transducer
D	Downward signal	UP	Upward / Up - upward starting command (card to control panel)
DAL	Auxiliary levelling device	V0	Speed : high
DIR	Direct	V1	Speed : medium
DLV A3	DLV A3 Valve	V2	Speed : inspection
DN	Downward	V3	Speed : fine levelling
FLT	Filter	VAL	Valve (Valve only)
ISP	Inspection gauge fitting	VB	Main flow adjustment valve
J	Jack	VC	Rupture valve
J 1:1	Direct Jack 1:1	VMD	Downward solenoid valve
K	Non-return valve	VML	Levelling solenoid valve
M, Ma	Motor	VMP	Starting solenoid valve (Y-D / SCC)
M1	VRP spool	VP	Pressure valve
MAN	Pressure gauge	VR	Non-return valve (flow outlet)
ML	Manual lowering button	VR1	Non-return valve (inlet)
MP	Motor / pump	VR2	Non-return valve (outlet)
MPS	Maximum pressure spool	VRa	Non-return valve (flow outlet) - Auxiliary
NGV	NGV Valve (Complete)	VRF	Flow regulation valve
NGV-A3	NGV A3 Valve (Complete)	VRFP	Ausiliary flow regulation valve
OFF	Powered off	VRP	Non-return valve - controlled
OLD, OVL	Full load pressure limit switch	VS	Pilot valve, Upward signal [NGV]
ON	Powered	VS1, VS10	Pressure safety valve
OPP	MPS pilot valve	VSMA	manual / electrical Lowering valve
P	VRP pilot spool	Y, Δ, Y-Δ	Star, Delta, Star-Delta